

The Bell of my Trumpet

For solo Trumpet and Electronics

Composed by

Austin Engelhardt

2020

Duration: approximately 10 Minutes

The Bell of my Trumpet

For solo Trumpet and Electronics

Composed by

Austin Engelhardt

2020

Instrumentation

- Trumpet in C
- Max Patch
- A Bell (larger bells preferred)

Performance Notes

- This piece calls for a Harmon mute.



- “X” note heads indicate the performer should strike their bell.

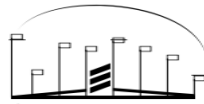

- Square note heads indicate breath tones, and three large lines indicate the gesture should have rapid finger movement. During these gestures, the performer should blow air through the instrument to produce breath tones while rapidly fingering the valves. No specific pitch is meant to be hit.

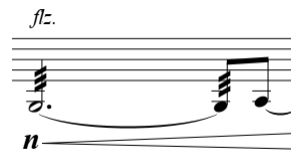

- Flutter tongue is indicated with “flz.”.



- When a second count appears above a fermata, it indicates the minimum amount of time the performer should wait before continuing.

Electronics

The piece utilizes the program MAX MSP for electronic processing. For the piece you will need.

Setup Diagram

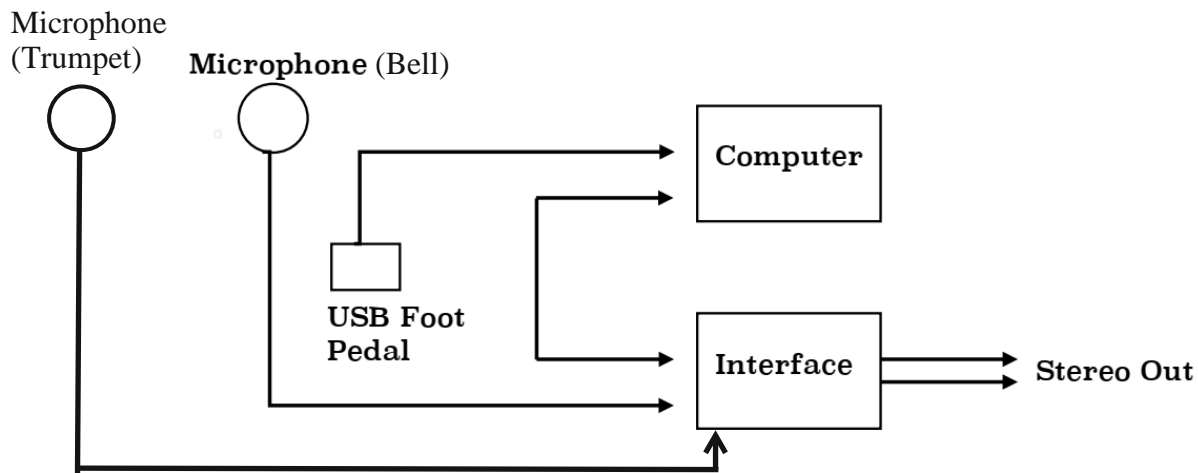

Pedaling: The piece utilizes a foot pedal to progress through the events of the electronics. These are indicated with a triangle note head paired with a number. (As seen below)



The Bell of my Trumpet

2
26

C Tpt.

Elec.

Play random pitches, in ascending order on fermata notes.

30

C Tpt.

Elec.

7

8

C Tpt.

Elec.

C Tpt.

Elec.

9

Wait for electronics to finish before moving on

C Tpt.

Elec.

10

The Bell of my Trumpet

In Time (♩=90)

C Tpt. 

Elec. 

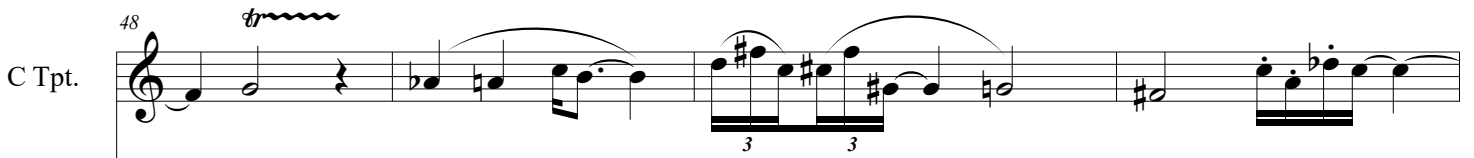
C Tpt. 

Elec. 

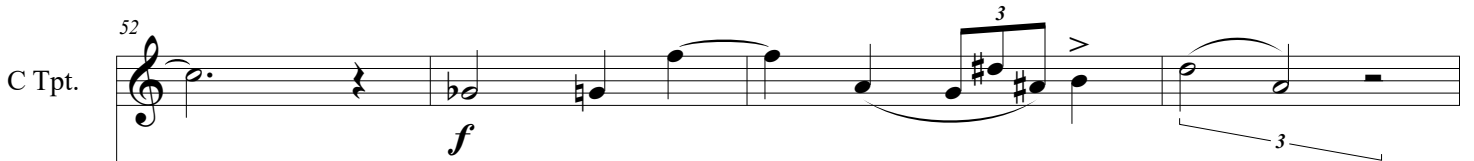
C Tpt. 

Elec. 

C Tpt. 

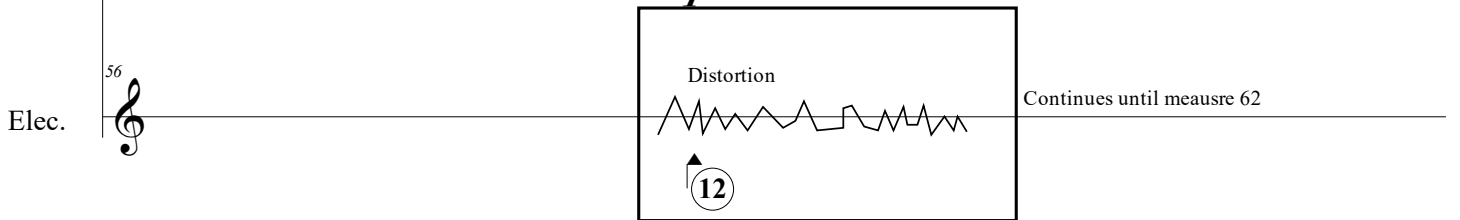
Elec. 

C Tpt. 

Elec. 

The Bell of my Trumpet

4

Harmon mute
No stem **Calm** ♩=60

C Tpt.

Use sustained pitch to take a moment to catch your breathe. *p*

Elec.

13 14

C Tpt.

68 *flz.* 5'' Open

Elec.

68 Delay Cloud 15

C Tpt.

72 *flz.* *mf*

Elec.

72 16

C Tpt.

76 *flz.*

Elec.

Allegro (M.M. ♩=c. 120)

C Tpt.

81 *f* *tr*

Elec.

The Bell of my Trumpet

Molto Rit.

C Tpt. 
mf *pp sff* *ppp*

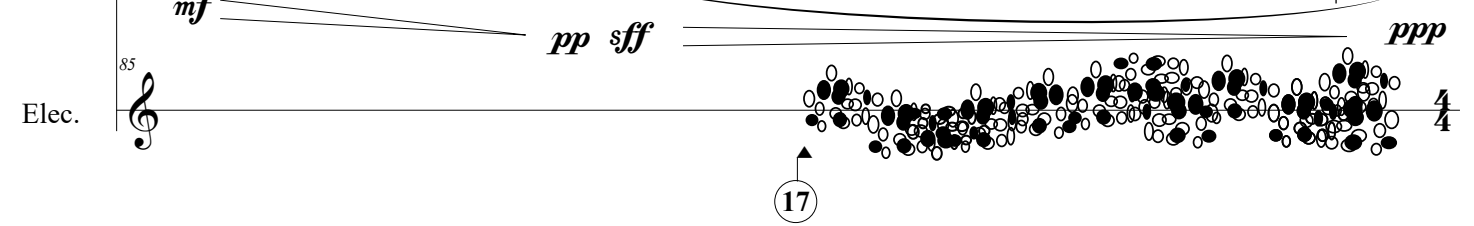
Elec. 
17

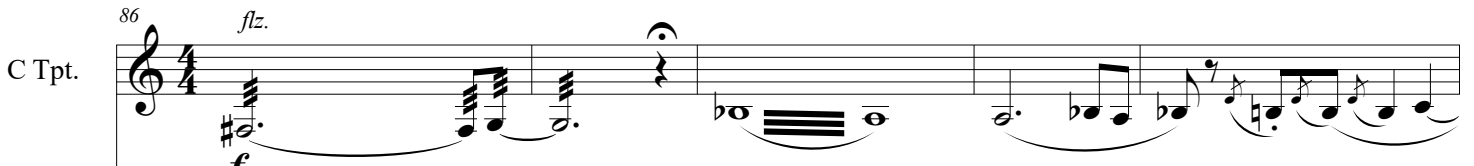
C Tpt. 
flz. *f*

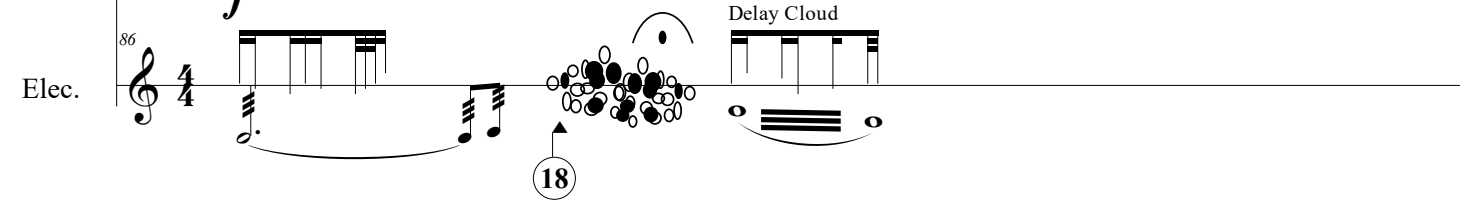
Elec. 
18

C Tpt. 

Elec. 

C Tpt. 
18

Elec. 

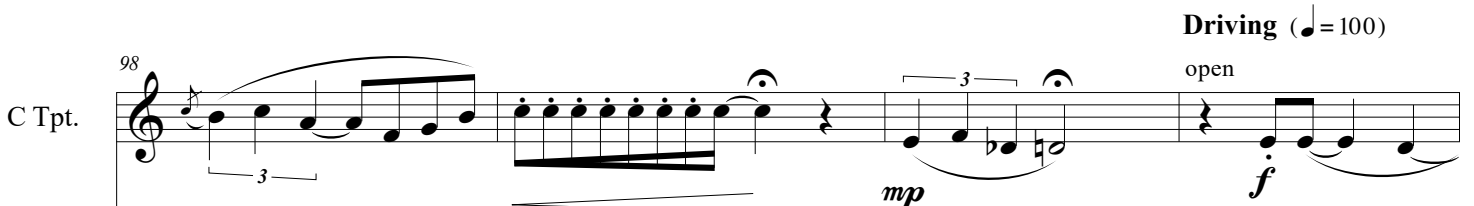
C Tpt. 
Driving (♩ = 100)
open *mp* *f*

Elec. 
19 20

The Bell of my Trumpet

6

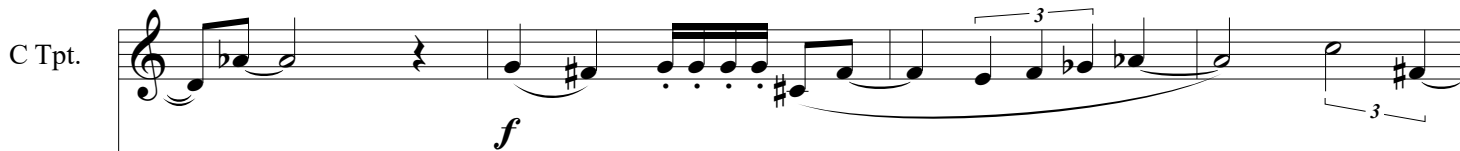
C Tpt. 

Elec. 

C Tpt. 

Elec. 

C Tpt. 

Elec. 

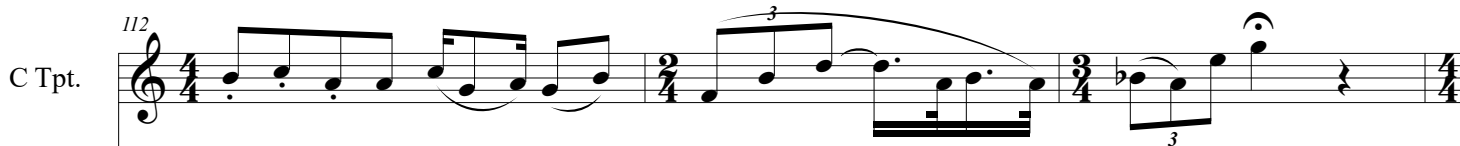
C Tpt. 

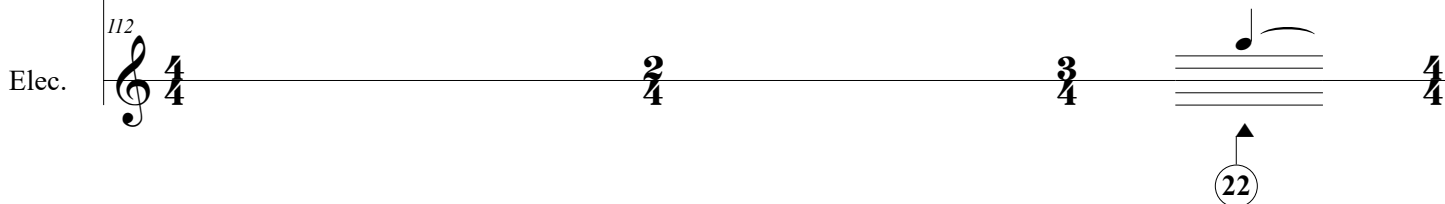
Elec. 

C Tpt. 

Elec. 

The Bell of my Trumpet

117

C Tpt.

Elec.

rit.

subito p

10"

C Tpt.

Elec.

ff

f

a tempo

23

122

C Tpt.

Elec.

mp

125

C Tpt.

Elec.

5/4

128

C Tpt.

Elec.

f

5/4 4/4 3/4 4/4

The Bell of my Trumpet

8
131

C Tpt.

Elec.

133

C Tpt.

Elec.

136

C Tpt.

Elec.

138

C Tpt.

Elec.

Delay Cloud

24

With everything you have

C Tpt.

Elec.

ff

25

The Bell of my Trumpet

143

C Tpt.

143

Elec.

146

C Tpt.

146

Elec.

Hold 15 seconds, then step on pedal and end.

p *f* *ff*

26

27